



**Consumables suitable for Trumpf®  
 Trumatic L2530, L3030, L3050, L4030, 6000L  
 L6030, L2503E, L3003E, L4003E, TC 600L**

**All nozzles packed in boxes of 10**

**Standard copper nozzles**

- 0124561
- 0124562
- 0966809
- 0237497
- 237497-S
- 237500
- 0237501
- 1253211
- 0126933
  
- 0942742
- 237504



- Nozzle Ø 0,8 mm.....
- Nozzle Ø 1,0 mm.....
- Nozzle Ø 1,2 mm.....
- Nozzle Ø 1,4 mm with step.....
- Nozzle Ø 1,4 mm with straight taper.....
- Nozzle Ø 1,5 mm.....
- Nozzle Ø 1,7 mm.....
- Nozzle Ø 2,0 mm.....
- Nozzle Ø 2,3 mm.....
- Nozzle Ø 2,5 mm.....
- Nozzle Ø 2,7 mm.....
- Nozzle Ø 3,0 mm.....

**Nozzles with hard chromium plating**

- 0352280
- 0352281
- 0352282
- 0352283
- 0352284
- 1253212
- 0352285
- 0352286



- Nozzle Ø 0,8 mm **Hard chromium plating**.....
- Nozzle Ø 1,0 mm **Hard chromium plating**.....
- Nozzle Ø 1,2 mm **Hard chromium plating**.....
- Nozzle Ø 1,4 mm **Hard chromium plating**.....
- Nozzle Ø 1,7 mm **Hard chromium plating**.....
- Nozzle Ø 2,0 mm **Hard chromium plating**.....
- Nozzle Ø 2,3 mm **Hard chromium plating**.....
- Nozzle Ø 2,7 mm **Hard chromium plating**.....

**Long copper nozzles**

*Shortens the distance to the old cutting edge and reduces the danger of collision (up-turned parts) !!*

- 1277773
- 1277771
- 1277774
- 1277776
- 1277779
- 1277780
- 1277781
- 1277782



- Nozzle Ø 0,8 mm.....
- Nozzle Ø 1,0 mm.....
- Nozzle Ø 1,2 mm.....
- Nozzle Ø 1,4 mm.....
- Nozzle Ø 1,7 mm.....
- Nozzle Ø 2,0 mm.....
- Nozzle Ø 2,3 mm.....
- Nozzle Ø 2,7 mm.....



**Long nozzles with hard chromium plating**

*Shortens the distance to the old cutting edge and reduces the danger of collision (up-turned parts) !!*

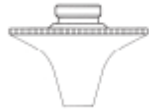

- Nozzle Ø 0,8 mm Hard chromium plating.....
- Nozzle Ø 1,0 mm Hard chromium plating.....
- Nozzle Ø 1,2 mm Hard chromium plating.....
- Nozzle Ø 1,4 mm Hard chromium plating.....
- Nozzle Ø 1,7 mm Hard chromium plating.....
- Nozzle Ø 2,0 mm Hard chromium plating.....
- Nozzle Ø 2,3 mm Hard chromium plating.....
- Nozzle Ø 2,7 mm Hard chromium plating.....

**Consumables suitable for Trumpf®  
Trumatic L2530, L3030, L3050, L4030, 6000L  
L6030, L2503E, L3003E, L4003E, TC 600L**

234485

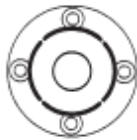

Break-away-bar.....

0258809



Ceramic nozzle holder(Lasermatic) -old Ref. 0353188  
*From an order of 10 pcs:*  
*From an order of 50 pcs:*

0260432



Ceramic nozzle holder DIAS III.....  
*From an order of 10 pcs*  
*From an order of 50 pcs*

216066



Locking nut.....

0225286



Teflon-Cover white (Lasermatic).....

254496



Teflon-Cover white.....





256153  
0955826



Teflon-Cover DIAS III white.....  
**Teflon-Cover DIAS III black.....**

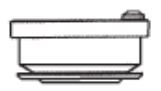



## Consumables suitable for Trumpf® Laser L1003/L2503/L3003/L4003

|  |   |  |
|--|---|--|
| 216066                                   |    | Locking nut.....   |
| 0258809                                  |    | Ceramic nozzle holder(Lasermatic) .....<br>old Ref. 0353188 <b>From an order of 10 pcs</b><br><b>From an order of 50 pcs</b> |
| <b>All nozzles packed in boxes of 10</b> |   |  |
| 215780                                   |    | Nozzle Ø 0,8 mm.....   |
| 087658                                   |   | Nozzle Ø 1,0 mm.....   |
| 088894                                   |   | Nozzle Ø 1,4 mm high pressure.....   |
| 217867                                   |   | Nozzle Ø 1,7 mm high pressure.....   |
| 088893                                   |    | Nozzle Ø 1,5 mm.....   |
| 221781                                   |   | Nozzle Ø 2,0 mm.....   |
| 235592                                   |   | Nozzle Ø 3,0 mm.....   |
| 216065                                   |  | Teflon-Cover white.....  |

## Consumables suitable for Trumpf® TruLaser® 5030, 5040 and 5060 (6/7KW Laser)

Nozzles are packed in strips of 10 tear-off bags

|         |   |                          |
|---------|---|--------------------------|
| 1324858 |  | Nozzle EAA Ø 0,8 mm..... |
| 1324860 |   | Nozzle EAA Ø 1,0 mm..... |
| 1324861 |   | Nozzle EAA Ø 1,2 mm..... |
| 1324863 |   | Nozzle EAA Ø 1,4 mm..... |
| 1324864 |   | Nozzle EAA Ø 1,7 mm..... |
| 1324865 |   | Nozzle EAA Ø 2,0 mm..... |
| 1324866 |   | Nozzle EAA Ø 2,3 mm..... |
| 1324867 | Nozzle EAA Ø 2,7 mm.....  |                          |
| 1373324 |  | Nozzle EAB Ø 0,8 mm..... |
| 1373325 |   | Nozzle EAB Ø 1,0 mm..... |
| 1373326 |   | Nozzle EAB Ø 1,2 mm..... |
| 1373327 |   | Nozzle EAB Ø 1,4 mm..... |
| 1373328 |   | Nozzle EAB Ø 1,7 mm..... |
| 1373329 |   | Nozzle EAB Ø 2,0 mm..... |
| 1373330 |   | Nozzle EAB Ø 2,3 mm..... |
| 1373331 | Nozzle EAB Ø 2,7 mm.....  |                          |



**Consumables suitable for  
 Trumpf® Laser TLC 105**

913965



Locking nut.....

**All nozzles packed in boxes of 10**

**Standard copper nozzles**

0212334

Nozzle Ø 1,0 mm.....

0216199

Nozzle Ø 1,0 mm HD.....

0225213

Nozzle Ø 1,4 mm HD.....

0126156

Nozzle Ø 1,7 mm HD.....

Nozzle Ø 2,3 mm HD.....

37364



"Shower" - Nozzle Ø 1,0 mm.....

226939

Nozzle Ø 1,0 mm.....

226940

Nozzle Ø 1,0 mm HD.....

227144

Nozzle Ø 1,4 mm HD.....

Nozzle Ø 1,7 mm HD.....

Nozzle Ø 2,3 mm HD.....

Nozzle Ø 1,0 mm.....

Nozzle Ø 1,4 mm HD.....

Nozzle Ø 1,7 mm HD.....

Nozzle Ø 2,3 mm HD.....

0135320

"Teach" Nozzle Ø 0,25 mm rough edged.....

Nozzle Ø 1,0 mm rough edged.....

Nozzle Ø 1,2 mm rough edged.....

Nozzle Ø 1,4 mm rough edged.....

Nozzle Ø 1,7 mm rough edged.....

0135318

0126157





**Nozzles with hard chromium plating**

|         |  |   |
|---------|--|---|
| 0212334 |  | Nozzle Ø 1,0 mm Hard chromium plating.....    |
| 0216199 |  | Nozzle Ø 1,0 mm HD Hard chromium plating..... |
| 0225213 |  | Nozzle Ø 1,4 mm HD Hard chromium plating..... |
| 0126156 |  | Nozzle Ø 1,7 mm HD Hard chromium plating..... |
|         |  | Nozzle Ø 2,3 mm HD Hard chromium plating..... |
| 226939  |  | Nozzle Ø 1,0 mm Hard chromium plating.....    |
|         |  | Nozzle Ø 1,0 mm HD Hard chromium plating..... |
| 226940  |  | Nozzle Ø 1,4 mm HD Hard chromium plating..... |
| 227144  |  | Nozzle Ø 1,7 mm HD Hard chromium plating..... |
|         |  | Nozzle Ø 2,3 mm HD Hard chromium plating..... |
|         |  | Nozzle Ø 1,0 mm Hard chromium plating.....    |
|         |  | Nozzle Ø 1,4 mm HD Hard chromium plating..... |
|         |  | Nozzle Ø 1,7 mm HD Hard chromium plating..... |
|         |  | Nozzle Ø 2,3 mm HD Hard chromium plating..... |
| 0135320 |  |   |
| 0135318 | Nozzle Ø 1,2 mm rough edged Hard chrom. plating. |   |
| 0126157 | Nozzle Ø 1,4 mm rough edged Hard chrom. plating. |   |
|         | Nozzle Ø 1,7 mm rough edged Hard chrom. plating. |   |

**Consumables suitable for  
 Trumpf® Laser TLC 1005**

|        |  |                  |
|--------|--|------------------|
| 913965 |  | Locking nut..... |
|--------|--|------------------|

**All nozzles packed in boxes of 10**

**Standard copper nozzles**

|         |  |                               |
|---------|--|-------------------------------|
| 0958206 |  | "Teach" Nozzle Ø 0,25 mm..... |
| 0913799 |  | Nozzle Ø 0,8 mm HD.....       |
| 0913800 |  | Nozzle Ø 1,0 mm HD.....       |
| 0913801 |  | Nozzle Ø 1,4 mm HD.....       |
| 0937988 |  | Nozzle Ø 1,7 mm HD.....       |
| 0937989 |  | Nozzle Ø 2,3 mm HD.....       |

**Nozzles with hard chromium plating**

|         |  |   |
|---------|--|---|
| 0913799 |  | Nozzle Ø 0,8 mm HD Hard chromium plating..... |
| 0913800 |  | Nozzle Ø 1,0 mm HD Hard chromium plating..... |
| 0913801 |  | Nozzle Ø 1,4 mm HD Hard chromium plating..... |
| 0937988 |  | Nozzle Ø 1,7 mm HD Hard chromium plating..... |
| 0937989 |  | Nozzle Ø 2,3 mm HD Hard chromium plating..... |